

LLC 35

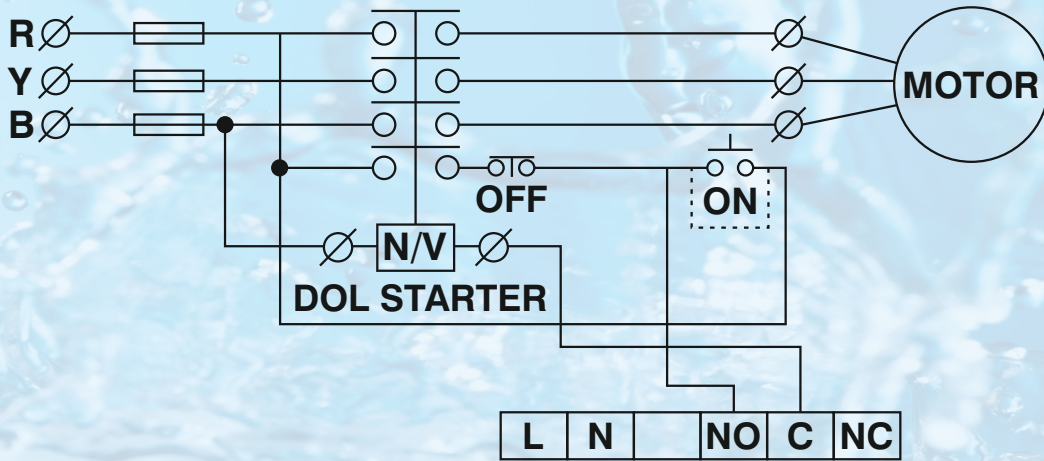
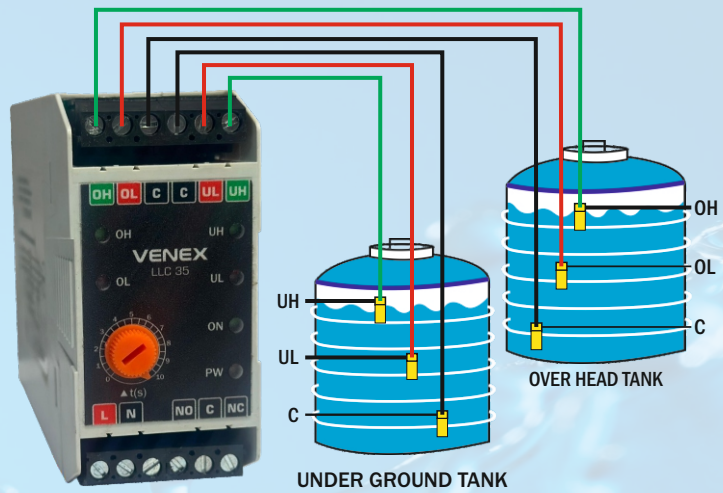

SPECIFICATION

| | |
|------------|------------------------------|
| Supply | 230 VAC, 50 Hz |
| Output | 1 Relay, 1 C/O, 5A |
| Input | SS Type / Float Sensor |
| Delay Time | 0 - 10 Sec. |
| Size | 75 X 35 X 105 mm (H X W X D) |

APPLICATIONS

- Perfect For Drain & Fill Control
- Water Distribution Pump Stations
- Submersible Pump Panels
- Soda Machines
- Textile Industry Setups
- Boiler Panels

High & Low Level Indication LED For Lower & Upper Tank Pump
Protection From Dry Run & Overflow Condition