

This section gives you all the information necessary to help you monitor and operate your controller including an Operator Interface overview, an explanation of the Displays, keys, LEDs, Mode access, and Operation Modes.



KEY OPERATION:

Keys	Functions
	To View & Edit Parameter And to be set Value And Move To The next Step.
	To Increment Parameter Value + STOP.
	To Decrement Parameter Value + START.
	Auto Or Manual Mode Selection.

SPECIFICATION

INPUT	<p>Volt Input R, Y, B, Three Phase (290 VAC ~ 490 VAC)</p> <p>CT Input 50 Ampere CT @ 3 NOs (1.0 AMP ~ 50.0 AMP)</p> <p>DT Input Digital Pressure Input</p>
OUTPUT	<p>Relay 3 CO, 40 Amp., 415 VAC</p>
<p>AUX. 415 VAC, 50 Hz, ± 10%</p> <p>Accuracy ± 1% of FSD</p> <p>Operating Temp. 0°C ~ 55°C</p> <p>Relative Humidity Up to 95% RH Non Condensing</p> <p>Enclosure Material ABS Plastic</p>	

Display Alphabet Characters

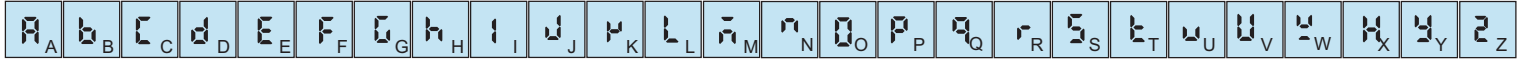

STARTING MENU

PRESS IF

CYC MODE (ENB)	CYT MODE (ENB)	DLF MODE (ENB)	DFT MODE (ENB)	NONE MODE
<p>4 15 Default Screen</p> <p>OFF</p> <p>Press </p> <p>0 70 Over Load Ampere</p> <p>0 L Use & </p> <p>Press </p> <p>0 0 0 Dry Run Ampere</p> <p>d-r-y Use & </p> <p>Press </p> <p>0 0 0 Dry Reset Time</p> <p>d-r-t Use & </p> <p>Press </p> <p>0 0 0 On Time (in Min.)</p> <p>0 n Use & </p> <p>Press </p> <p>0 0 0 Off Time (in Min.)</p> <p>OFF Use & </p> <p>Press </p> <p>0 0 0 Auto Time (in Sec.)</p> <p>A-t-a Use & </p> <p>Press </p> <p>- - - Save & Exit</p> <p>- - -</p>	<p>4 15 Default Screen</p> <p>OFF</p> <p>Press </p> <p>0 70 Over Load Ampere</p> <p>0 L Use & </p> <p>Press </p> <p>0 0 0 Dry Run Ampere</p> <p>d-r-y Use & </p> <p>Press </p> <p>0 0 0 Dry Reset Time</p> <p>d-r-t Use & </p> <p>Press </p> <p>0 0 0 On Time (in Min.)</p> <p>0 n Use & </p> <p>Press </p> <p>0 0 0 Off Time (in Min.)</p> <p>OFF Use & </p> <p>Press </p> <p>0 0 0 Auto Time (in Sec.)</p> <p>A-t-a Use & </p> <p>Press </p> <p>- - - Save & Exit</p> <p>- - -</p>	<p>4 15 Default Screen</p> <p>OFF</p> <p>Press </p> <p>0 70 Over Load Ampere</p> <p>0 L Use & </p> <p>Press </p> <p>0 0 0 Dry Run Ampere</p> <p>d-r-y Use & </p> <p>Press </p> <p>0 0 0 Dry Reset Time</p> <p>d-r-t Use & </p> <p>Press </p> <p>0 0 0 On Time (in Min.)</p> <p>0 n Use & </p> <p>Press </p> <p>0 0 0 Auto Time (in Sec.)</p> <p>A-t-a Use & </p> <p>Press </p> <p>- - - Save & Exit</p> <p>- - -</p>	<p>4 15 Default Screen</p> <p>OFF</p> <p>Press </p> <p>0 70 Over Load Ampere</p> <p>0 L Use & </p> <p>Press </p> <p>0 0 0 Dry Run Ampere</p> <p>d-r-y Use & </p> <p>Press </p> <p>0 0 0 Dry Reset Time</p> <p>d-r-t Use & </p> <p>Press </p> <p>0 0 0 On Time (in Min.)</p> <p>0 n Use & </p> <p>Press </p> <p>0 0 0 Auto Time (in Sec.)</p> <p>A-t-a Use & </p> <p>Press </p> <p>- - - Save & Exit</p> <p>- - -</p>	<p>4 15 Default Screen</p> <p>OFF</p> <p>Press </p> <p>0 70 Over Load Ampere</p> <p>0 L Use & </p> <p>Press </p> <p>0 0 0 Dry Run Ampere</p> <p>d-r-y Use & </p> <p>Press </p> <p>0 0 0 Dry Reset Time</p> <p>d-r-t Use & </p> <p>Press </p> <p>0 0 0 Auto Time (in Sec.)</p> <p>A-t-a Use & </p> <p>Press </p> <p>- - - Save & Exit</p> <p>- - -</p>

Password	Cyclic Function With Trigger	Delay Time
Enable Function	Phase Sequence Function	Dry Reset Time
Auto Delay Time	Cyclic Function	Ampere Offset Value
None Mode	Function Disable	Difference Value
Mode Selection	Function Yes	R Phase Offset
Delay Off Time Fuction	High Voltage Function	Low Voltage Function
SPP Function (Phase Loss)	Limit For Ampere Setting	Y Phase Offset
Delay Off Time With Trigger Function	Start Delay Time (Initial Delay)	B Phase Offset



PARAMETER SETTING

PRESS  For 5 Sec.



Time Parameter

Ampere Parameter



Voltage Parameter

043 Default Screen
 P45 Use  & 

Press 

030 Enter Password
 P45 030 For Time Parameter
 Use  & 



Press 

d15 «» Enb
 AEr Auto Delay Time
 Use  & 



Press 

n0n » dLF » dFE
 A0d Mode Selection
 C4C « C4E

Press 



n0 «» 4E5
 AEr Memory Retain
 Use  & 

Press 



025 Percentage Setting
 PEr Use  & 

Press 



--- Save & Exit

043 Default Screen
 P45 Use  & 



Press 

070 Enter Password
 P45 070 For Ampere Parameter
 Use  & 



Press 

300 Max. Ampere Limit Setting
 LAr Use  & 



Press 

010 Start Delay Time Setting
 SAr Use  & 



Press 

005 Ampere Delay Time Setting
 dLr Use  & 



Press 

Enb «» d15
 d-r Dry Run Function
 Use  & 

Press 



Enb «» d15
 d-rE Dry Reset Time Setting
 Use  & 

Press 



000 Ampere Offset Value Setting
 A0F Use  & 

Press 



--- Save & Exit

043 Default Screen
 P45 Use  & 



Press 

090 Enter Password
 P45 090 For Voltage Parameter
 Use  & 



Press 

Enb «» d15
 SPP SPP Function
 Use  & 



Press 

Enb «» d15
 SFA Phase Sequence
 Use  & 



Press 

Enb «» d15
 HU High Voltage
 Use  & 



Press 

490 High Voltage
 HU Use  & 



Press 

Enb «» d15
 LU Low Voltage
 Use  & 



Press 

320 Low Voltage
 LU Use  & 



Press 

005 Voltage Delay Time Setting
 dLr Use  & 



Press 

050 Voltage Difference For Phase Lose
 d1F Use  & 



Press 

000 R Phase Offset Value Setting
 r0F Use  & 

Press 

000 Y Phase Offset Value Setting
 y0F Use  & 

Press 

000 B Phase Offset Value Setting
 b0F Use  & 

Press 

--- Save & Exit

Wiring Diagram

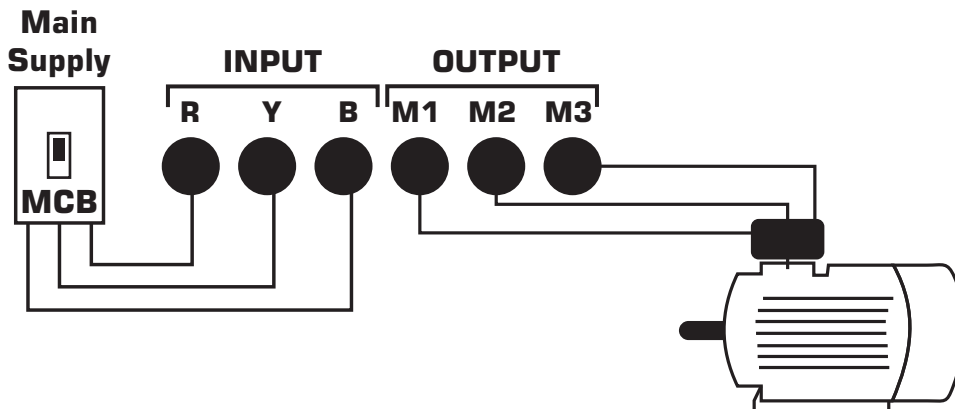

Warranty and Application Considerations

Read and Understand This Catalog

Please read and understand this catalog before purchasing the products. Please consult your venex representative if you have any questions or comments.

Warranty and Limitations of Liability

WARRANTY

(12 Months, unless agreed otherwise by us) We undertake to replace or repair at our option any defective product that needs replacement or repair, by reason of defective workmanship or defective materials, brought to our notice within the period specified below as "Warranty Period" after delivery to the buyer, providing also that it we so require, the part in respect of which a complaint is made must, before liability can be entertained under this clause, be sent at buyer's expense to our works or our office, as we may determine. Under no circumstances do we undertake liability for indirect or consequential loss or damage of any nature. This guarantee is given in lieu of and excludes every other condition or warranty whether statutory or otherwise.

LIMITATIONS OF LIABILITY

VAPL Shall Not Be Responsible For Special, Indirect, Or Consequential Damages, Loss Of Profits, Or Commercial Loss In Any Way Connected With The Products, Whether Such Claim Is Based On Contract, Warranty, Negligence, Or Strict Liability.

In no event shall the responsibility of VAPL for any act exceed the individual price of the product on which liability is asserted

In No Event Shall VAPL Be Responsible For Warranty, Repair, Or Other Claims Regarding The Products Unless VAPL's Analysis Confirms That The Products Were Properly Handled, Stored, Installed, And Maintained And Not Subject To Contamination, Abuse, Misuse, Or Inappropriate Modification Or Repair.

Application Considerations

SUITABILITY FOR USE

VAPL shall not be responsible for conformity with any standards, codes, or regulations that apply to the combination of products in the customer's application or use of the products. Take all necessary steps to determine the suitability of the product for the systems, machines, and equipment with which it will be used.

Know and observe all prohibitions of use applicable to this product.

Never Use The Products For An Application Involving Serious Risk To Life Or Property Without Ensuring That The System As A Whole Has Been Designed To Address The Risks, And That The VAPL Products Are Properly Rated And Installed For The Intended Use Within The Overall Equipment Or System.

DISCLAIMERS

PERFORMANCE DATA

Performance data given in this catalog is provided as a guide for the user in determining suitability and does not constitute a warranty. It may represent the result of VAPL's test conditions, and the users must correlate it to actual application requirements. Actual performance is subject to the VAPL Warranty and Limitations of Liability.

CHANGE IN SPECIFICATIONS

Product specifications and accessories may be changed at any time based on improvements and other reasons. Consult with your VAPL representative at any time to confirm actual specifications of purchased product.

DIMENSIONS AND WEIGHTS

Dimensions and weights are nominal and are not to be used for manufacturing purposes, even when tolerances are shown.

SAFETY PRECAUTIONS

Do not touch the terminals while power is being supplied. Doing so may occasionally result in minor injury due to electric shock.



Do not allow pieces of metal, wire clippings, or fine metallic shavings or filings from installation to enter the product. Doing so may occasionally result in electric shock, fire, or malfunction.



Do not use the product where subject to flammable or explosive gas. Otherwise, minor injury from explosion may occasionally occur.



Never disassemble, modify, or repair the product or touch any of the internal parts. Minor electric shock, fire, or malfunction may occasionally occur



If the output relays are used past their life expectancy, contact fusing or burning may occasionally occur. Always consider the application conditions and use the output relays within their rated load and electrical life expectancy. The life expectancy of output relays varies considerably with the output load and switching conditions



Tighten the terminal screws to between 0.74 and 0.90 N-m. Loose screws may occasionally result in fire.



Set the parameters of the product so that they are suitable for the system being controlled. If they are not suitable, unexpected operation may occasionally result in property damage or accidents.



A malfunction in the Temperature Controller may occasionally make control operations impossible or prevent alarm outputs, resulting in property damage. To maintain safety in the event of malfunction of the Temperature Controller, take appropriate safety measures, such as installing a monitoring device on a separate line.



VBTRON AUTOMATION PVT. LTD.

132, Vishala industrial Estate,
Nr. Odhav Ring Road Circle,
Kathwada, Ahmedabad.
(GUJARAT) INDIA

Authorized Distributor :

© VBTRON AUTOMATION PVT. LTD. 2014
All Right Reserved. In the interest of
product improvement, specifications are
subject to change without notice.

PRECAUTIONS FOR SAFE USE

Be sure to observe the following precautions to prevent operation failure, malfunction, or adverse effects on the performance and functions of the product. Not doing so may occasionally result in unexpected events.

- The product is designed for indoor use only. Do not use the product outdoors or in any of the following locations.
 - Places directly subject to heat radiated from heating equipment.
 - Places subject to splashing liquid or oil atmosphere.
 - Places subject to direct sunlight.
 - Places subject to dust or corrosive gas (in particular, sulfide gas and ammonia gas).
 - Places subject to intense temperature change.
 - Places subject to icing and condensation.
 - Places subject to vibration and large shocks.
- Use/store within the rated temperature and humidity ranges. Provide forced-cooling if required.
- To allow heat to escape, do not block the area around the product. Do not block the ventilation holes on the product.
- Be sure to wire properly with correct polarity of terminals.
- Use specified size (M3.5, width 7.2 mm or less) crimped terminals for wiring. To connect bare wires to the terminal block, use copper braided or solid wires with a rated temperature of over 70° C and a gauge of AWG24 to AWG14 (equal to a cross-sectional area of 0.205 to 2.081 mm²). (The stripping length is 5 to 6 mm.) Up to two wires of same size and type, or two crimped terminals can be inserted into a single terminal.
- Do not wire the terminals which are not used.
- Allow as much space as possible between the controller and devices that generate a powerful high-frequency or surge. Separate the high-voltage or large-current power lines from other lines, and avoid parallel or common wiring with the power lines when you are wiring to the terminals.
- Use this product within the rated load and power supply.
- Make sure that the rated voltage is attained within two seconds of turning ON the power using a switch or relay contact. If the voltage is applied gradually, the power may not be reset or output malfunctions may occur. into consideration when performing control.
- Make sure that the Controller has 30 minutes or more to warm up after turning ON the power before starting actual control operations to ensure the correct temperature display.
- A switch or circuit breaker should be provided close to this unit. The switch or circuit breaker should be within easy reach of the operator, and must be marked as a disconnecting means for this unit.
- Do not use paint thinner or similar chemical to clean with. Us standard grade alcohol.
- Design system (control panel, etc) considering the 2 seconds of delay that the controller's output to be set after power ON.
- The output may turn OFF when shifting to certain levels. Take this into consideration when performing control.
- The number of non-volatile memory write operations is limited